

S.4 MATHEMATICS SCENARIO BASED DISCUSSION ITEMS
ALL ITEMS CARRY 20 SCORES
PLEASE ATTEMPT AS MANY ITEMS AS POSSIBLE

ITEM ONE:

A certain member of your family re-wrote each digit of his 4-digit **ATM** card pin from number system ten (base ten) to another number system less than four. He did this in fear of theft. Now he is sick in the hospital, he can neither talk nor write but the money on his account is needed to finance hospital bills. Here is how he wrote the pin: 12 20 22 10. Assuming that you have been able to encrypt the **ATM** pin for the family and funds are available to take care of him. The hospital has a nurse who takes checks on him after every two hours and a medical doctor who checks on him after every four and half hours. Both medical personnel last checked on him together at **9: 30am**. He was treated well and discharged and advised as follows. He was advised to spend three—eighths of the day resting, one sixth of the day eating, two thirds of the remainder having a healthy diet and the rest of time of the day visiting the hospital for further checkup.

TASKS:

- (a) (i) Which number system do you think he used to re-write the pin and why?
- (ii) Use the identified number system to help your family members to regenerate the original pin.
- (b) (i) At what time did will both the nurse and medical doctor check on him again at the same time.
- (c) How many hours of the day in a week does he have spend on visiting the hospital.

ITEM TWO:

A produce wholesale dealer in Kalerwe Farmers Market has a broker who has been helping him order for his produce on his half. However he has been informed that his broker left for Saudi Arabia in quest for greener pastures, he is much troubled yet he wants to order for **1200 bags** of produce. He visited his business books and noticed that in January, when he bought **300 bags**, the cost of transporting each bag was **UGX4500** and in February when he bought **700 bags**, the cost of transporting each bag was **UGX8500**. He has resorted to do the ordering and buying by himself.

In preparation for Easter he went to Luuka Village to buy some produce with his lorry. Unfortunately his Lorry broke down and opted for two vehicles a Pickup and an Isuzu Diana. The pickup can transport **18 bags** while the Isuzu Diana can transport **30 bags**. The number of bags to be transported must exceed **120**. Each trip the Pickup and Isuzu Diana makes cost **UGX240, 000** and **UGX300, 000** respectively yet he has allocated **UGX2, 400, 000** to cater for transport.

The number of trips made by the pickups should not exceed those made by the Isuzu Diana by more than **2**.

TASKS:

- (a) Determine the cost the whole sale dealer will pay for the **1200 bags**.
- (b) Help the dealer obtain how many trips each vehicle will make in order to minimize the cost of transport.

ITEM THREE:

There is a quarantine of all cattle and goats in some parts of Western Uganda especially Mbarara District. The area honorable Member of parliament (M.P) wants to throw for his constituents a celebration party for the success of the Parish Development Model (PDM) and he has invited a lot of guests. However due to the quarantine he can not buy any animals from Mbarara and he has been advised to go to Kayunga where cheap cattle and good Yoghurt can be found. He moves from Mbarara to Masaka which is **160km** North of Mbarara. From Masaka he moves west wards **150km** to Kampala. From Kampala he heads to Mukono which is in the direction **S75°W** which is **90km** from Kampala. From Kampala he heads to Kayunga which is **148km** and south of Mukono.

When he reached Kayunga he bought **400** cows and each costs **UGX850,000** per cow. The farmer and owner of the cow first gives a **5%** discount on each cow plus an additional **10%** discount for any number of cows bought in excess of **250**.

In order to package the yoghurt, he bought two identical types of buckets. A smaller bucket with a base radius of **30cm** and a larger bucket with a base radius of **50cm**. He intends to use the buckets to keep the Yoghurt for his guests. The capacity of the smaller bucket is **45 litres** and he is to buy **4** smaller buckets and **2** larger buckets.

TASKS.

- (a) Direct the honorable MP on the shortest route he should take and the shortest distance between Mbarara and Kayunga.
- (b) Find the total cost he incurred in purchasing the cows.
- (c) What is the maximum amount of Yoghurt he bought for his guests.

ITEM FOUR:

Holy Prayers Ministries International for a long time has been soliciting money to construct a church which can accommodate all the church members. The Senior Pastor has a vision of a Hexagonal church which can fit exactly in the plot of land available. He wants to know the actual cost of constructing the church. He also has to buy a Sino Truck to transport all building materials and requirements. The contractor informs him that the area of each triangle that can be formed from the hexagonal church will cost him **UGX 128,000,000**.

He then proceeded to Nina Motors to buy the Sino truck. A brand new Sino Truck costs four hundred eighty millions on cash. It can also be bought by paying a deposit of a quarter of the cash price value and either pay **UGX7.5 millions** weekly for **50 weeks** or pay **24.5 millions** monthly for **15 months**. The pastor does not have the required money to obtain the Sino Truck on cash.

TASKS:

- (a) Help the pastor determine the cost of the church.
- (b) How much extra will he pay for the Sino Truck and explain why. (25 scores)

ITEM FIVE:

A school head teacher is thinking of how he can boost the mathematics department of your school. He can either add another teacher or buy more books or both. He has decided that he will do both if the average performance for this year's performance for the 40 students is lower than that of the previous which was **47**. He asked the department to give a test and the these were the student's marks.

50	71	40	48	61	70	30	62
44	63	60	51	55	25	32	65
54	45	65	50	45	40	25	45
48	45	30	38	30	28	24	48
30	48	28	35	50	48	50	60

He also visited the library and found out that the previous's candidates used three books for there revision. Longhorn, Baroque or Maths Clinic. From the librarian's records its is clear that all the candidates that did not use any book failed the subject greatly. Out of the **35** candidates this year **13** used Longhorn, **20** used Baroque and **17** used Maths Clinic. **9** used Longhorn and Maths Clinic, **3** used Longhorn and Baroque while **8** used Baroque and Maths Clinic only. The records show that **2** used all the three books. He observed that he should replace one book type of the three with Fountain publisher since no student read it only alone.

TASKS:

- (a) (i) Help the head teacher group the marks to make an informed decision one the fate of the department and defend it.
- (ii) Display the students marks in groups on a simple statistics diagram.
- (b) (i) Help the head teacher identify the book he should replace and explain why?
- (ii) Find the probability that a student selected from the class failed.

ITEM SIX:

Three schools from a Gayaza region want to participate in the National Schools Football Sports Gala to be held in Lyantonde district play ground. Unfortunately none of the schools has a school bus and they want to hire a bus for the one day for the activity. The bus charges 25,000km per km moved. The three schools through there Sports master agreed to share the cost of the bus equally amongst them selves. One that day they hired a bus from your school in Gayaza and they set off at **4: 30am** and increased the speed gradually to **90km/hr** reaching Mpigi at **6: 45am**. From there the bus driver maintained this same speed for $2\frac{1}{4}$ hours reaching Masaka. From Masaka the he reduced slowly in speed reaching Lyantonde at **9: 30am**. The games started at **10: 00am** sharp and each team played six games.

School A won **3** games, drew **2** and lost **1** game. School B won **4** games and lost **2** games. School C won **2** games and drew **4** games. The organizers award three points for a win, one point for a draw and no point for a loss. They declared these schools the first three schools in order of their points they obtained from the games. They were to receive the price money of sixteen millions five hundred thousand shillings.

TASKS:

- Find how much each school paid for the bus.
- Decide the cash prize for school.

ITEM SEVEN

A man intends to plant trees on the two sides of the road which leads to his land. On one side of the road, he is to plant a tree every after **5m** yet on the other side he is to plant a tree every after **6m**. at the start of the road, two trees are to be planted directly opposite each other. In the first phase of planting trees, he will plant trees, until another pair of tress is again directly opposite. His land has an area of $500m^2$. He plans to use **25%** of the land to plant maize, one fifth of the land for beans and $205m^2$ dor growing ground nuts.

Tasks:

- Help the man determine how many tree seedlings he needs to buy to just plant this first phase.
- Determine in m^2 the size of the land to be used for growing maize.
- Determine in m^2 the size of the land to be used for growing beans.
- Express the area to be used for growing ground nuts in standard form.
- Do you think he partitioned the entire land properly? Give a reason.

ITEM EIGHT

A mathematician gave your friend a carpenter a task of making a rectangular ground floor of a rabbit house. The length of the house is to be $(x + 3)m$ and the width is to ym . Its perimeter should be $25m$ and its area msut be $25m^2$. The mathematician adds that he needs the work to be finished in one day but he has ever contracted **3 men** working at the

same rate and they only managed to work on $5m^2$. To be given this contract, your friend is required to make a clear diagram showing the numerical sizes of the length and width but fails to do so and comes to you for help.

Tasks:

- (a) (i) Determine the length and width of the floor to be occupied by the house.
- (ii) Make a sketch of the floor your friend can present to the mathematician to get the contract.
- (b) Determine the number of workers who are needed to complete the house if they all work at the same rate as the group the man has ever used.

ITEM NINE

A friend of yours wanted to participate in the National Ludo Champions competitions. During his practice, he rolled a die several times and kept on taking a picture of each occurrence. He needs to find out whether he will compete favorably but he is unable to do so. He gives you the diagram below showing his scores so that you can guide him.

Tasks:

- (a) Use the information above and clearly show how to determine the score with the highest chance of occurring on top. Which score is it?

- (b) Find the probability that an odd number occurred when the die was rolled.
- (c) Present the information of the above scores on a statistical graph.
- (d) Will your friend compete favorably in the competitions? Give a reason.

ITEM TEN

An organization wants to build a school in a certain community. Below were the reasons they identified as to why children were not schooling.

A =school is boring. **B** =no school fees. **C** =we want to work.

They carried out research on a sample of **50** children in that community to find out which reason has the highest probability amongst the above and hence base on that to either build the school or not. Children gave one reason, others gave two and the others gave three as shown below.

A	B,C	B	A,C	A	B,C	B	A,C	A,B,C	B
C,B	B	B,C	A,B,C	A,C	B	C	B	C	B
B	A,B,C	B,A	A	B	A	C,B	A,B	B,A	C
C	A,C	B,A	B	C,B	C	C	A	B	B,C
A,C	B	A	A	C	B,A	C	B	A	A,C

Tasks:

- (a) Present the data in such a way that the total responses for each reasons **A**, **B** and **C** respectively are clearly shown
- (b)
 - (i) Which reason has the highest probability?
 - (ii) What is the probability?
 - (iii) Basing on the value of probability should they build the school or not? Give a reason for your answer.

ITEM ELEVEN

A carpenter is re-known for crafting traditional wooden doors with elaborate geometric patterns. The carpenter wishes to make a door with a circular design at its center. The carpenter needs to ensure the design fits perfectly within the rectangular frame of the door. The door frame available is rectangular with dimensions **2.5meters** in height and **1.5meters** in width. The circular design should be touching the two parallel sides of the door frame. Vanish is packed in tins of a litre and the cost of one litre of vanish is **UGX 9,000**. It is known that one litre of vanish can be used to paint one square meter.

Tasks:

- (a) (i) Help the carpenter determine how much of the door will be covered by the circular design so that it fits perfectly within the door frame.
- (ii) Will one tin of vanish be enough for the circular design? Give a reason for your response.
- (b) With a reason(s), help the carpenter determine how much will be spent to buy vanish that will paint the entire front face of the door.

ITEM TWELVE

You are an athlete and soon competing with someone. You wanted to test your chances of winning the race by testing your speed and time in relation to that of your competitor you started to run at **4: 50pm**. From your home where you started from, you ran a distance of **5km** north–west to place **P**, then from **P**, you turned south and ran **4km** until you were at place **Q** that is west of your home and then ran back and arrived at **5: 12pm**. Your competitor ran the same distance during training at a speed of **10m/s**.

Tasks:

- (a) What is the total distance that you ran?
- (b) What is the total time you took to run that distance?
- (c) How fast were you?
- (d) (i) Do you think you will win the race or not?
- (ii) Why do you think that way?

ITEM THIRTEEN:

A school head teacher is thinking of how he can boost the mathematics department of your school. He can either add another teacher or buy more books or both. He has decided that he will do both if the average performance for this year's performance for the 50 students is lower than that of the previous which was **64**. He asked the department to give a test and the these were the student's marks.

86	30	26	64	87	47	49	26	43	25
45	38	44	56	59	52	76	27	89	46
90	57	73	48	58	89	51	32	56	88
66	62	52	67	69	68	49	92	66	95
54	74	32	39	35	36	69	50	71	92

He also visited the library and found out that the previous's candidates used three books for there revision. Longhorn, Baroque or Maths Clinic. From the librarian's records its is clear that all the candidates that did not use any book failed the subject greatly. Out of the **35** candidates this year **13** used Longhorn, **20** used Baroque and **17** used Maths Clinic.

9 used Longhorn and Maths Clinic, **3** used Longhorn and Baroque while **8** used Baroque and Maths Clinic only. The records show that **2** used all the three books. He observed that he should replace one book type of the three with Fountain publisher since no student read it only alone.

TASKS:

- (a) (i) Help the head teacher group the marks to make an informed decision on the fate of the department and defend it.
- (a) (ii) Display the students marks in groups on a simple statistics diagram.
- (b) (i) Help the head teacher identify the book he should replace and explain why?
- (b) (ii) Find the probability that a student selected from the class failed.

ITEM FOURTEEN

St. JULIAN is to transport its S. 4 students for fieldwork in Kasenyi. All the 400 students are to be transported using either coasters or buses. Each coaster can carry 40 people while each bus can carry 80 people. The transport department of the school has only 8 drivers on duty and up to four coasters. If the cost of hiring a coaster is shs. 150,000 and that of hiring a bus is shs. 300,000.

While in Kasenyi their geography teacher Mr Kefa visited Mr Sembatya's shop from which he found that three shirts and two trousers cost shs. 105,000 at Mr. Sembatya's shop. Two shirts and five trousers cost shs. 180,000 at the same shop;

Task:

- (a) (i) Write down the five inequalities representing the above information.
- (a) (ii) Represent the inequalities on a graph paper.
- (a) (iii) Find the possible number of coasters and buses that can be used and hence determine the minimum cost.
- (b) Find the cost of;
 - (i) each shirt and each trouser.
 - (ii) three items of each type at the shop.

ITEM FIFTEEN:

Simon is the district inspector of schools in Butambala district found that his casual workers use one third of his farm for bananas, one quarter for coffee and two fifth of the remainder for mixed farming. She still has some six acres of unused land.

Buddo S.S has a student population of 1200 students. On a particular day Simon invited the entire for a , $\frac{1}{5}$ of the boys and $\frac{1}{4}$ of the girls went to **WAKISSHA** resource centre for a sports meeting. If 936 students were left behind.

The price of Simon's house was valued at 45 million shillings. It increased by 25% after the first year but in the second year, the value of the house depreciated by 10%.

Task:

- Find the size of his farm and clearly illustrate it on a diagram.
- Find how many more boys than girls attended the meeting.
- Find the value of her house at the end of the second (2nd) year.

ITEM SIXTEEN:

Kampala (K) and Arua (A) are about 450km apart. At 7:30 a.m, a bus starts from Arua and moves towards Kampala (K) at a steady speed of 100km/hr while a lorry starts from Kampala (K) an hour later moving at an average speed of 60km/hr to Arua (A). At 10.00 a.m, the bus is stopped at town C by police and ordered to reduce speed. After 30 minutes at C, it resumes its journey at a reduced average speed of 50km/hr until it reaches Kampala (K).

Task:

- State the difference in time when the two vehicles arrive at their destinations.
- Determine when and at what distance from Arua the two vehicles meet.
- Find the average speed of the bus.

ITEM SEVENTEEN:

You are only two children in the family and the chairperson of your village has come to your home to register the details of you and your sibling. Unfortunately both parents are not around and you he gives them a call to find your present ages. The mother informs him that the two ages differ by 4. the father informs him that the sum of the squares of your ages is 136.

Your neighbor makes a rectangular flower bed by taking two meters off its length and adding three meters to its breadth. By so doing, he increases the area by 20 square meters. Moses is 1.5m tall and standing on top of a building 34m tall. In a straight line from where he is standing he can see a car and bicycle at angles of depressions of 50° and 65° respectively.

A magician on Easter day organized a presentation in your village to entertain the village. He had a bag that contains x red balls and $(x - 8)$ white balls. If the probability of drawing a red ball is $\frac{2}{3}$.

Tasks:

- (a) Help the chairperson get the right ages of you and your sibling.
- (b) What is its final area of the flower bed?
- (c) How far is the bicycle from the car?
- (d) Find the number of balls in the bag.

ITEM EIGHTEEN

The cost of manufacturing Blue band in a factory is determined by the components milk x and flavor y . If the constraints for the production are $3y + 2x \leq 15$, $2x - 3y \leq 5$, $x \geq 1$ and $y \geq 0$. The factory has only chicken and goats. When the manager counted the heads of the stock in the farm, the number totalled to 200. When the number of legs was counted, the number totalled to 540.

Task

- (a) Given that the cost function for the production of blue band is $c = x + 2y$ find the;
 - (i) Minimum cost
 - (ii) Maximum cost
- (b) How many chickens were there on the farm?

ITEM NINETEEN

Your parents are organizing to celebrate your 18th birthday and want it to be a memorable one. They went to Akamwesi mall which has a CINEMAX and it has two tickets. Tickets to a play cost 9 dollars for adults and 5 dollars for children. If the show sold 180 tickets and earned 1380 dollars,

George your brother has been planning for this birthday for three weeks. He buys the following items in three weeks. Week one he buys 2 packets of tea, 2 tins of margarine, 3 kg of sugar and 4 packets of biscuits. Week two he buys 2 tins of margarine, 3 kg

of sugar and 4 packets of biscuits. Week three he buys 2 packet of tea, 2 kg of sugar and 3 packets of biscuits. A packet of tea costs shs 1,000, a tin of margarine costs shs 2,500, a kilogramme of sugar costs shs 3,500 and a packet of biscuits costs shs 2000. Your parents then demarcated the land they are to use for the party and plan to demarcate it. represented the plot of land he inherited using the following inequalities. $40x + 60y \geq 480$... (i) $30,000x + 45,000y < 600,000$... (ii) $x \leq 12$... (iii) $y \geq 2x$... (iv)

He wants to fence it using poles(x) and barbed wire (y) and the cost function is given by

$$C = 45000x + 30,000y$$

Task;

- (a) how many of each type of tickets were sold?
- (b) Find his total expenditure in the three weeks.
- (c) find the maximum cost.

ITEM TWENTY

The length of a rectangular plot of land exceeds the width by 7ft and its area is 60sq. ft. Three business partners Wambusa, Aisha and Wekesa contributed Shs 300.000, 500.000 and 700.000 respectively to start a business. They decided that $\frac{1}{3}$ of the profit was to be ploughed back to the business, $\frac{1}{5}$ of the remainder would be kept for emergencies and the rest to be shared in the ratio of their capital contributions. In that year the profit realized was one and a quarter times that of capital.

Task:

- (a) Find the dimensions of the rectangle
- (b) Determine the amount received by each partner that year.

ITEM TWENTY ONE

A bucket is in shape of a frustrum with an open end of diameter 30cm and a bottom diameter of 20cm. the bucket which is 42cm deep is used to fill an empty cylindrical tank of diameter 1.8m and Height 1.2m

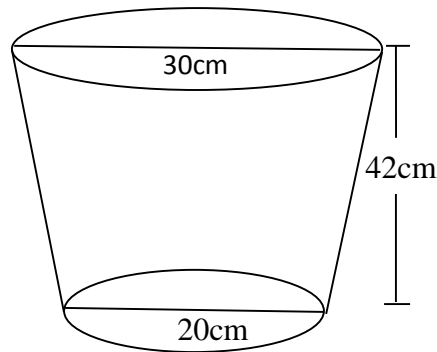

Taking $\pi = 3.142$.

Three hundred and sixty litres of a homogeneous paint is made by mixing three paints **A**, **B** and **C**. The ratio by amount of point **A** to point **B** is 3:2 and that of **B** to **C** is 1:2. Paint **A** costs shs 1800 per litre paint **B** costs shs 2400 per litre and paint **C** shs 1,275 per litre

Task:

- (a)
 - (i) Determine the capacity of the bucket in litres correct to 3dp.
 - (ii) The capacity of the tank in litres correct to 2 dp.
 - (iii) The number of bucket that must be drawn to fill the tank.
- (b)
 - (i) The amount of each paint in the mixture
 - (ii) The amount of money need to make 1 litre of the mixture
 - (iii) The percentage profit made by selling the mixture at shs 2,210 per litre.

ITEM TWENTY TWO

There are very few teachers who have three teaching subjects. A survey was done in your school and it was found that the school has a teaching staff of 22 teachers 8 of them teach mathematics, 7 teach physics and 4 teach Chemistry. Three teach both mathematics and Physics and one teaches Mathematics and Chemistry. No teacher teaches all the three

subjects. The number of teachers who teach Physics and Chemistry is equal to that of those who teach Chemistry but not physics.

In the school staffroom there are two similar cans that have different heights. One 6cm and the other one 9cm. If the surface area of the larger can is 840 cm^2 .

Task

- (a) Find the number of teachers who teach none of the three subjects.
- (b) Find the probability that a teacher picked at random teaches only one subject.
- (c) Find the surface area of the smaller can.

ITEM TWENTY THREE

The traffic police arrests all motorists travelling along Kampala-Jinja highway with a speed greater than 80km/hr. A motorist travelled the first 90 km at an average speed of 60 km/hr and for the next $3\frac{1}{2}$ hours he travelled at an average speed of 80 km/hr.

On a certain day a car travelling at s km/hr can be stopped within a distance d metres

where $d = \frac{s^2}{200} + \frac{s}{10}$ The table below gives some values of d against s .

s	0	10	20	30	40	50	60	70	80	90	100
d	0			7.5				31.5			60

- (a) Find out if the motorist will be arrested.
- (b) Find the stopping distance for a car moving at 46 km/hr and at 85 km/hr. Also find the speed at which a car is moving if its stopping distance is 35 metres.

ITEM TWENTY FOUR

In a survey 100 people were asked which form of transport they used. 46 people only used bicycles (M). 21 people only used buses (N). 11 people only used motor bikes (P). 5 people used buses and bicycles but not motor bikes. 3 people used buses and motor bikes. 6 people used bicycles and motor bikes. 9 people declined to respond.

Customs duty and purchase tax are levied on certain imported goods as

Customs duty = 35% of the value of the good.

Purchase tax = 15% of (value + duty)

Task

- (a) Find the;
 - (i) number of people who used all the three forms of transport.
 - (ii) percentage of people who used only two forms of transport.

(b) Find the total amount levied on a disco deck valued at 1.7 millions.

ITEM TWENTY FIVE

The figure below shows a net of a right pyramid with a rectangular base ABCD.

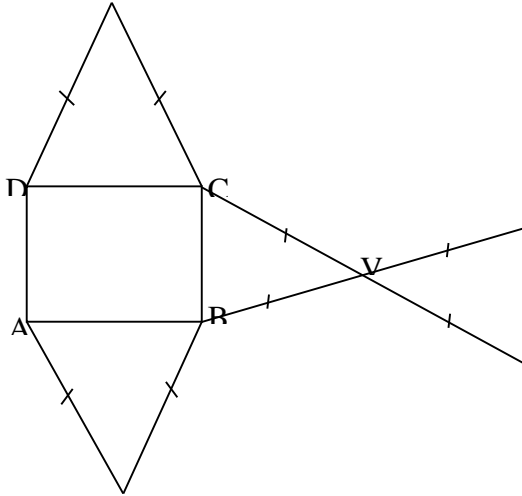

If **V** is the vertex of the pyramid **VABCD** above the base **ABCD**, $AB = 16\text{cm}$, $BC = 12\text{cm}$, and the slant sides of each triangle measure 26cm .

- a) Draw the right pyramid showing clearly points VABCD,
- b) Find the height of the pyramid.
- c) Find the area of plane VAB
- d) Find the angle between;
 - (i) Edge VA and the base
 - (ii) Face VAB and the base.

ITEM TWENTY SIX

Mr kyeswa is buying a container to start a hardware in Kisooba Village to sell bags of cement. Each bag occupies an area of 0.8cubic meters . The container is $ABCDEFGH$ with $AB = 12\text{m}$, $BC = 9\text{m}$, $ADEF$ is a square and O is the point of intersection of AC and BD .

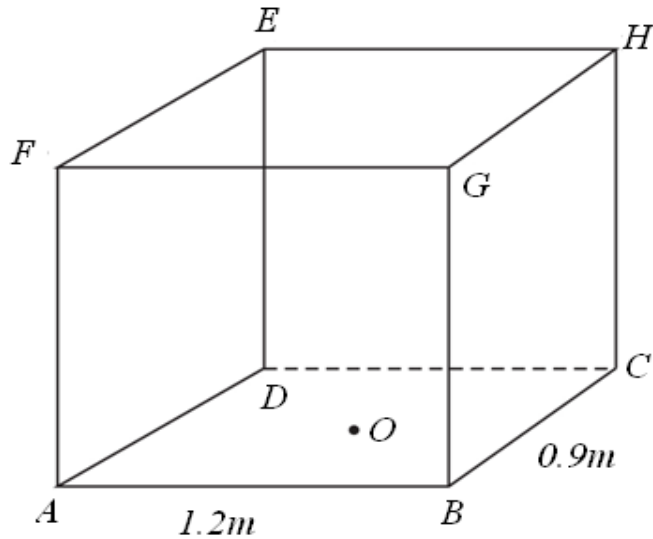

- (a) Find the distances;
- (i) BE ,
 - (ii) OH .
- (b) Determine the angle formed between;
- (i) line BE and the base,
 - (ii) plane BDH and the base.
- (c) Calculate the capacity of the cuboid above in litres and how many bags can be accommodated.

ITEM TWENTY SEVEN

Pamungu bought a car in January 2017 from his friend at shs. 12,500,000. If the car depreciates at a rate of 10% per annum. Calculate the value of Pamungu's car by January 2020.

A Ugandan tourist left Germany for Uganda through Switzerland. While in Switzerland he bought a watch worth 54 Deutsche Marks (Germany currency).

$$1 \text{ Swiss Franc} = 1.28 \text{ Deutsche Marks}$$

$$1 \text{ Swiss Franc} = 1,350 \text{ Ugandan Shillings}$$

A secondary school teacher as a requirement by the government pays PAYE every month according to the tax structure below.

Income (shs) per month	Tax rate(%)
01-50,000	5%
50,001 - 100,000	9.5%
100,001 - 180,000	15%
180,001 - 300,000	18%

300,001 - 400,000	23%
400,001 - 500,000	30%
Above 500,000	35%

The teacher earns Shs.760,000 and his allowances include

- Marriage allowance - shs.50,000 per month
- Water and electricity - shs.60,000 per month
- Housing allowance - shs 150,000 per month
- Medical allowance - shs.300,000 per annum
- Transport allowance - shs.3,000 per day
- Paying for insurance and relief - shs.180,000 per annum

Family allowance for only three children. For children in the age bracket 0 to 10 years, shs 12,000 per child,
 Between 10-15 years shs. 9000 per child
 15 years and above shs 5000.

Given that the employee has five children, two of whom are aged between 0 and 10, the other two aged between 10 and 15 while the other 18 years. (A month has 30 days

- (a) Find the value of the watch in;
 - (i) Swiss Francs
 - (ii) Ugandan Shillings.
- (a) Determine the teacher's Net-income
- (b) Determine the percentage of his gross income that goes to tax.

FOR MORE DETAILS CALL 0703-684687 OR WATSUP ON 0787762458 FOR ORDERS OF:

NEW LOWER CURRICULUM MATHS CLINIC S.1&S.2

NEW LOWER CURRICULUM MATHS CLINIC S.3&S.4

SUBSIDIARY MATHS CLINIC 2024 EDITION.

PURE MATHS CLINIC 2024 EDITION

(PHANEROO-MAKE MANIFEST)